

Figure

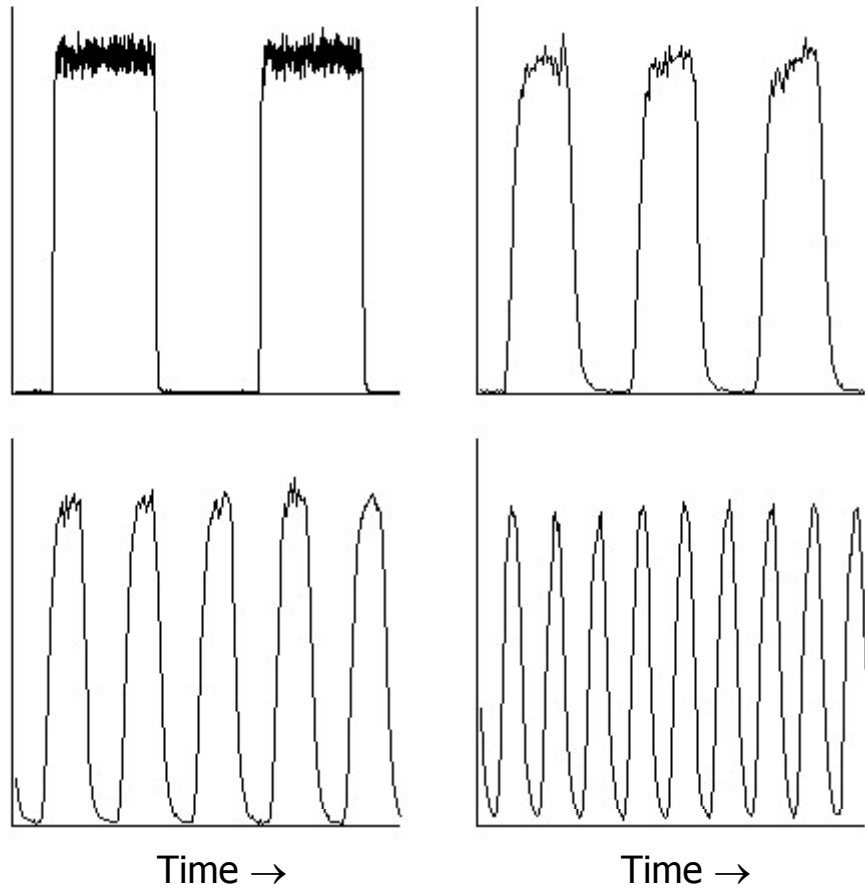

Figure

Note: Data from "20080125_w/MFM" (new HAIS instrument)

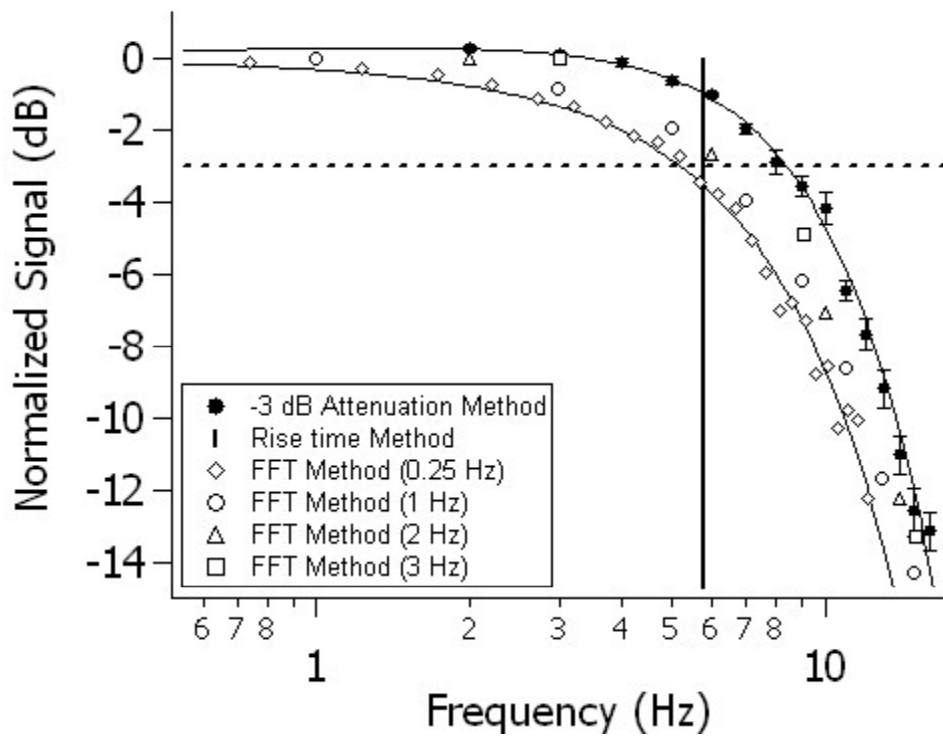

Figure

Note: Data from “20080125_w/MFM” (new HAIS instrument)

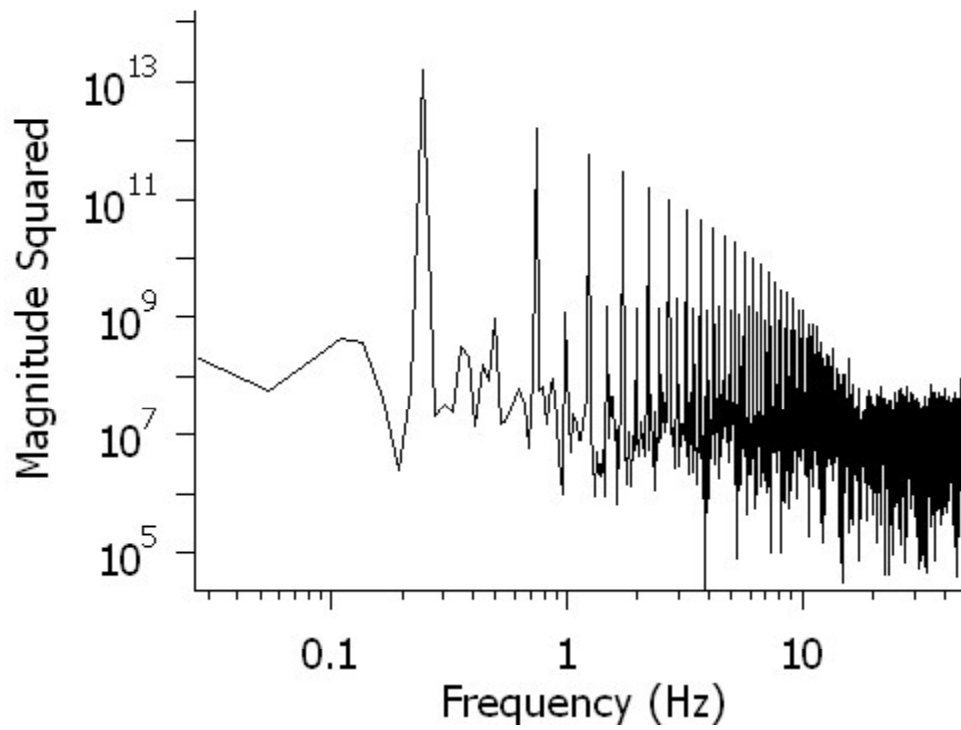

Figure

Note: Data from "PASE TF04", (old instrument)

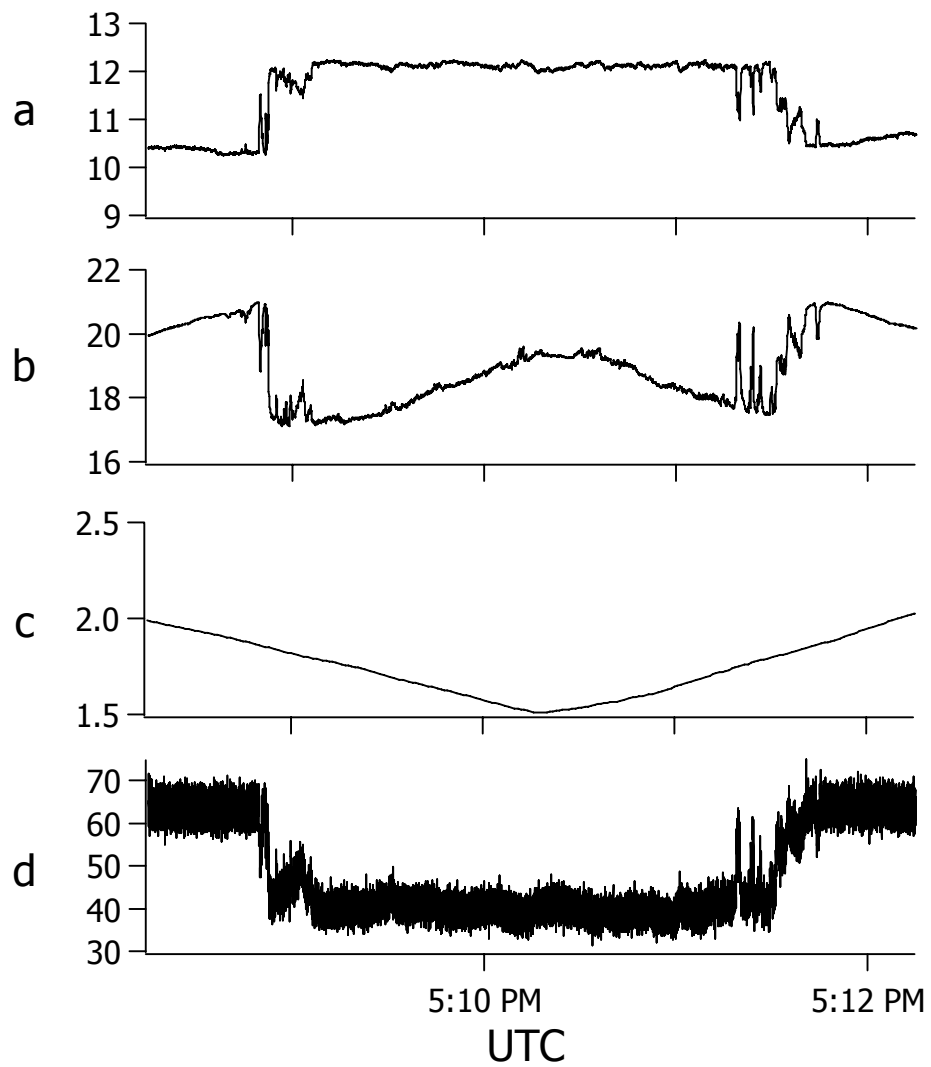

Figure

Note: Data from "PASE TF04" (zoomed in version of previous)

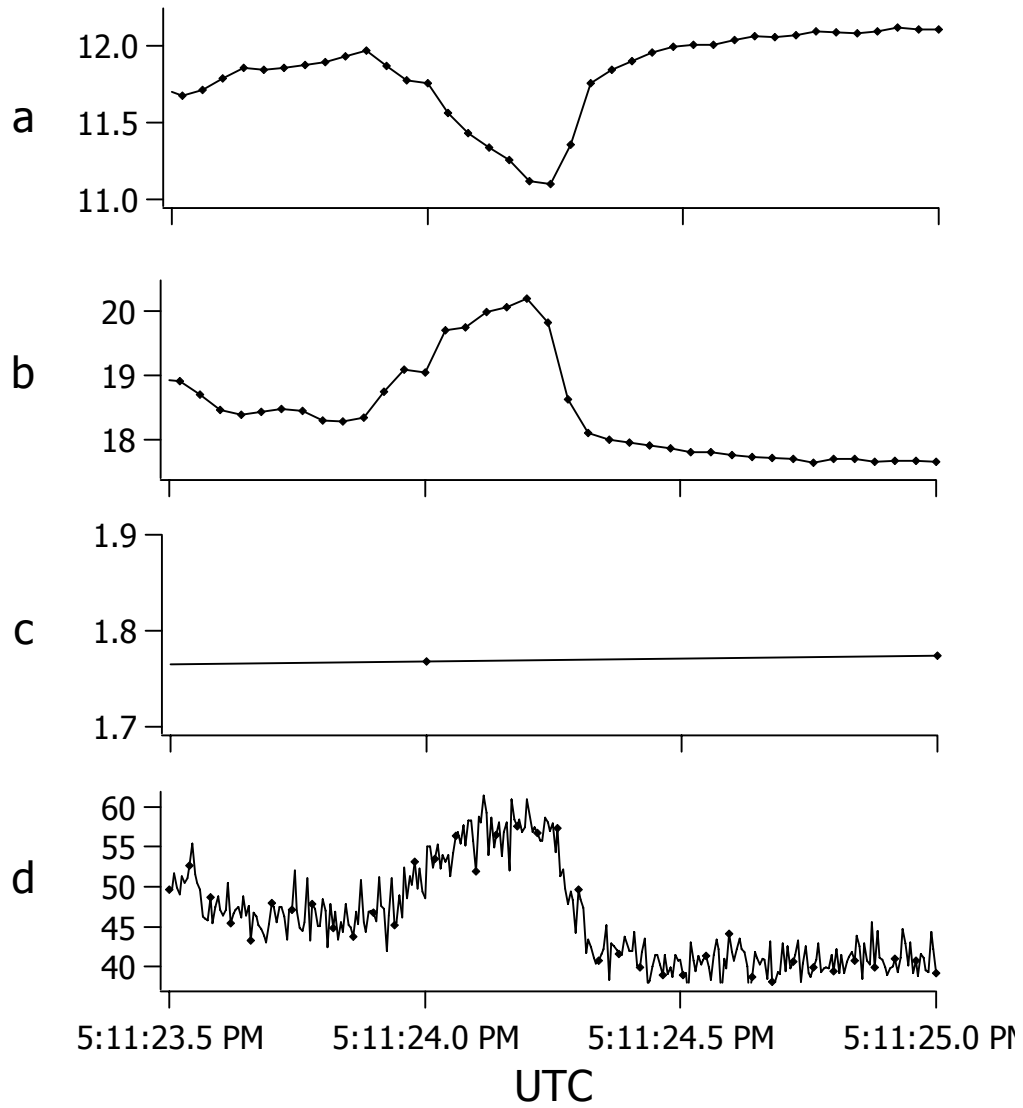

Figure

Note: O3 Data from "PASE TF04", (old instrument), different time segments

Power spectra

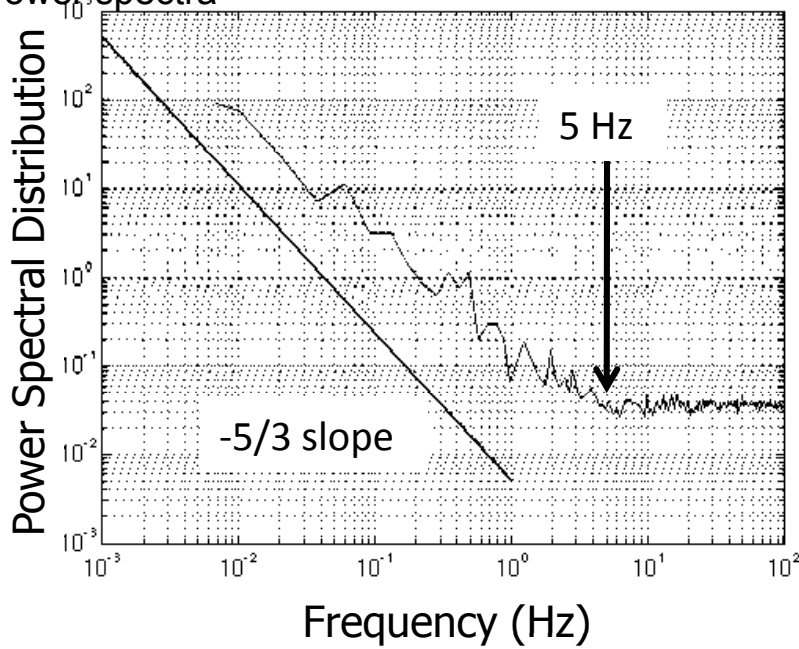

9) From: NC plot
Smoothed?

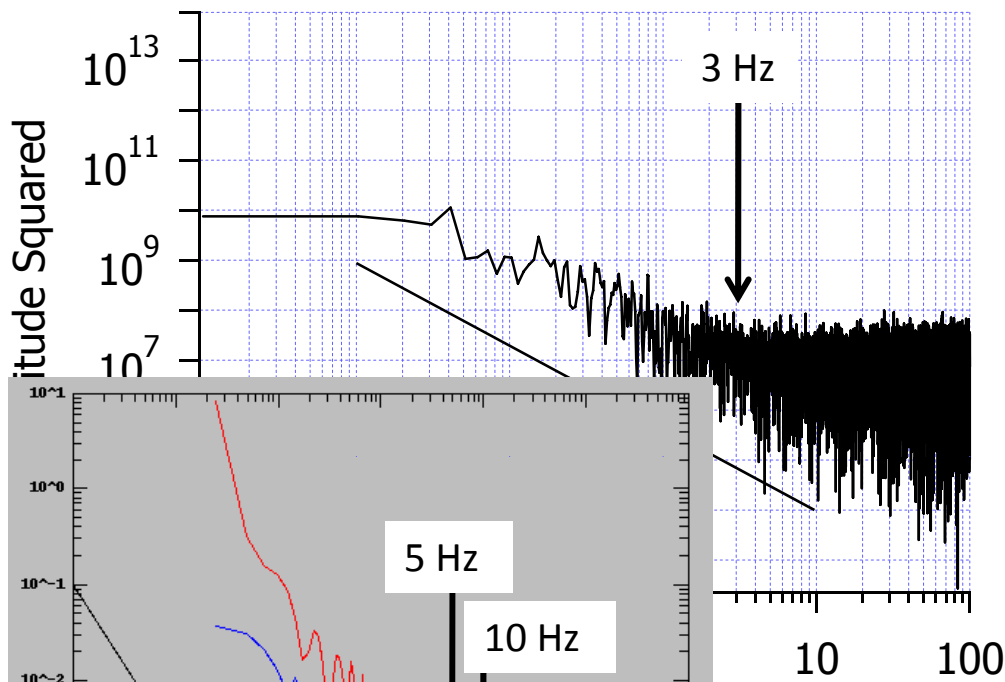

9a) From:
FFT in IGOR

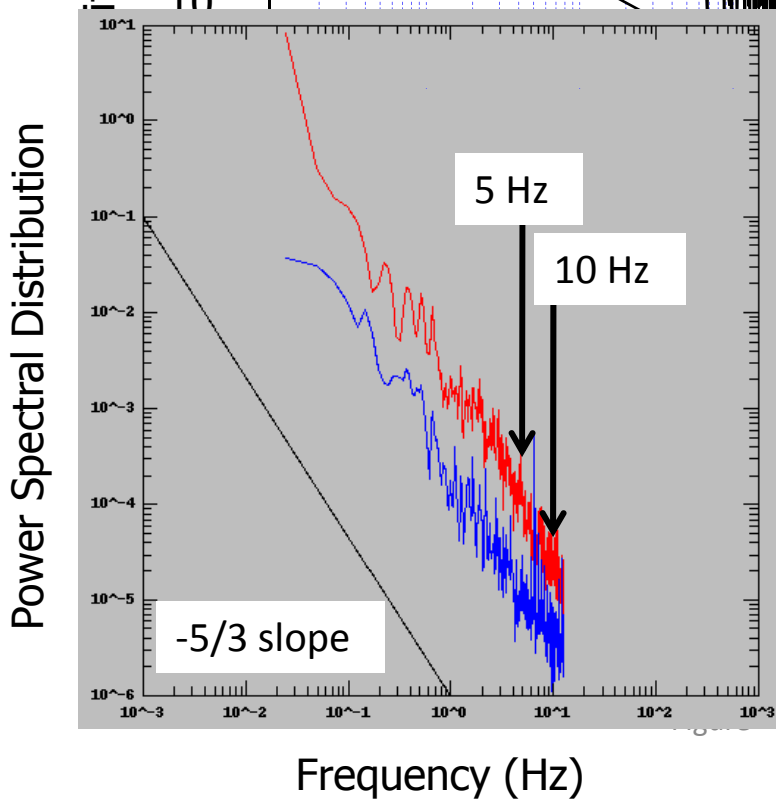

Note: O3 Data from "PASE TF04", (old instrument), different time segments
Cospectra

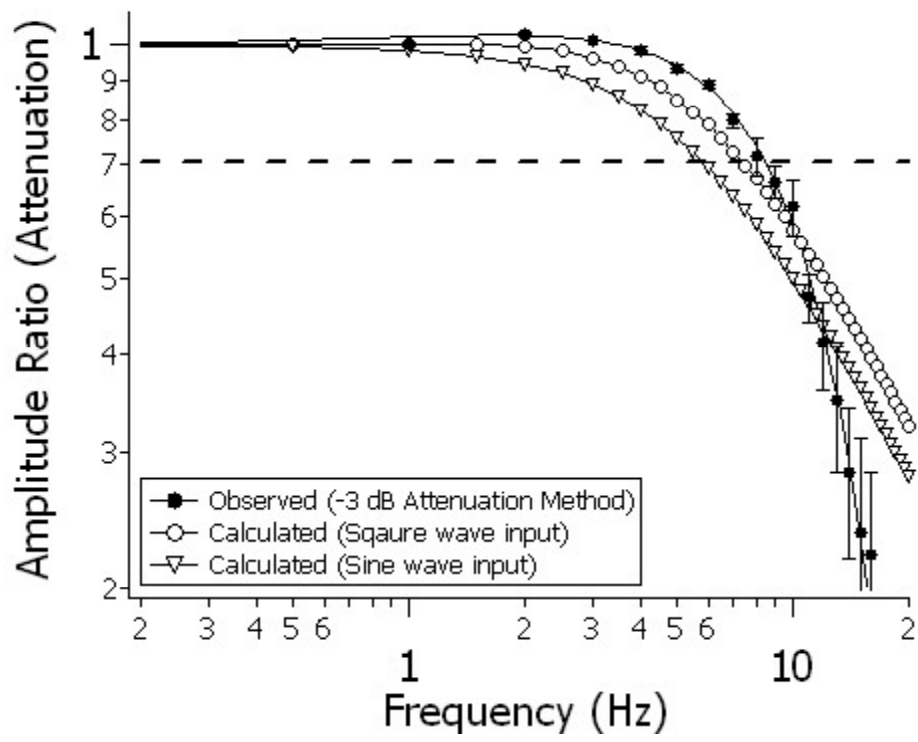

Figure

Note: O3 Data from "PASE TF04", (old instrument), same time segments

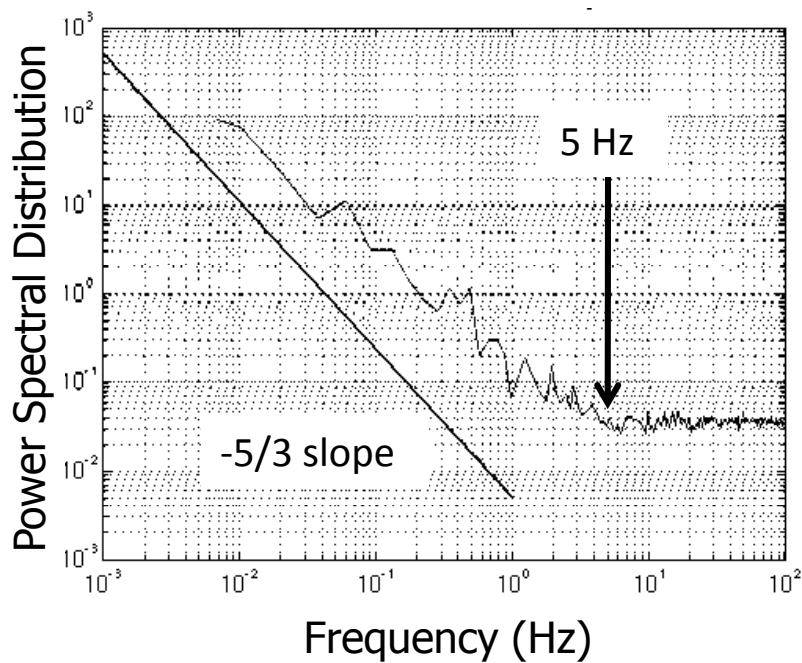

9) From: NC plot
Smoothed?

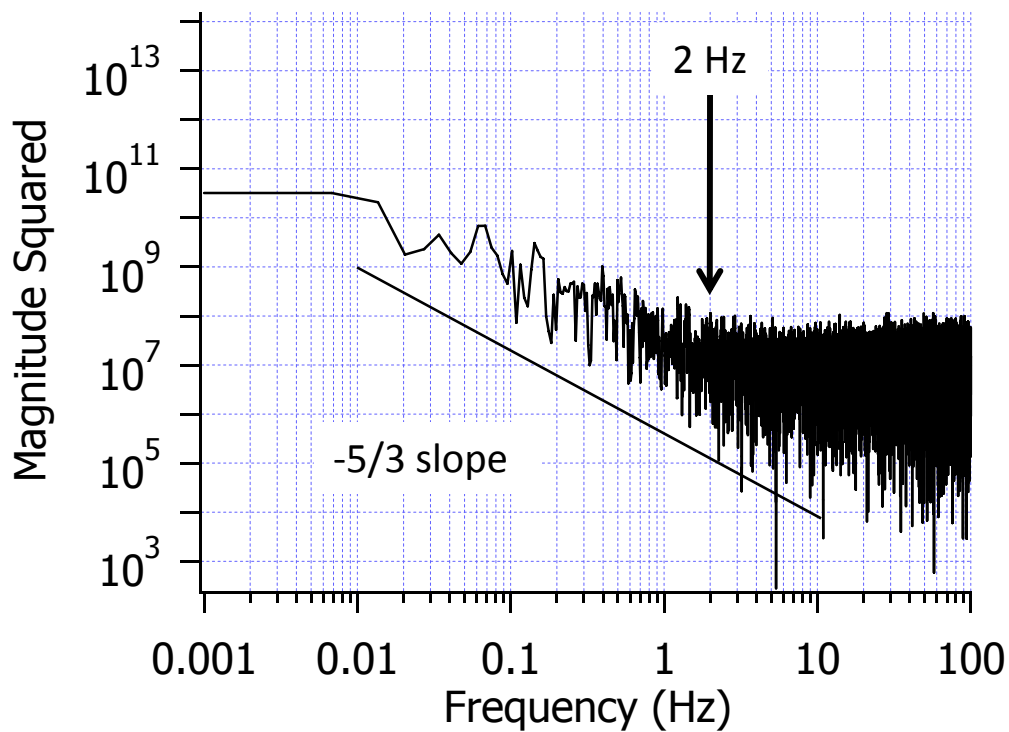

9a) From:
FFT in IGOR

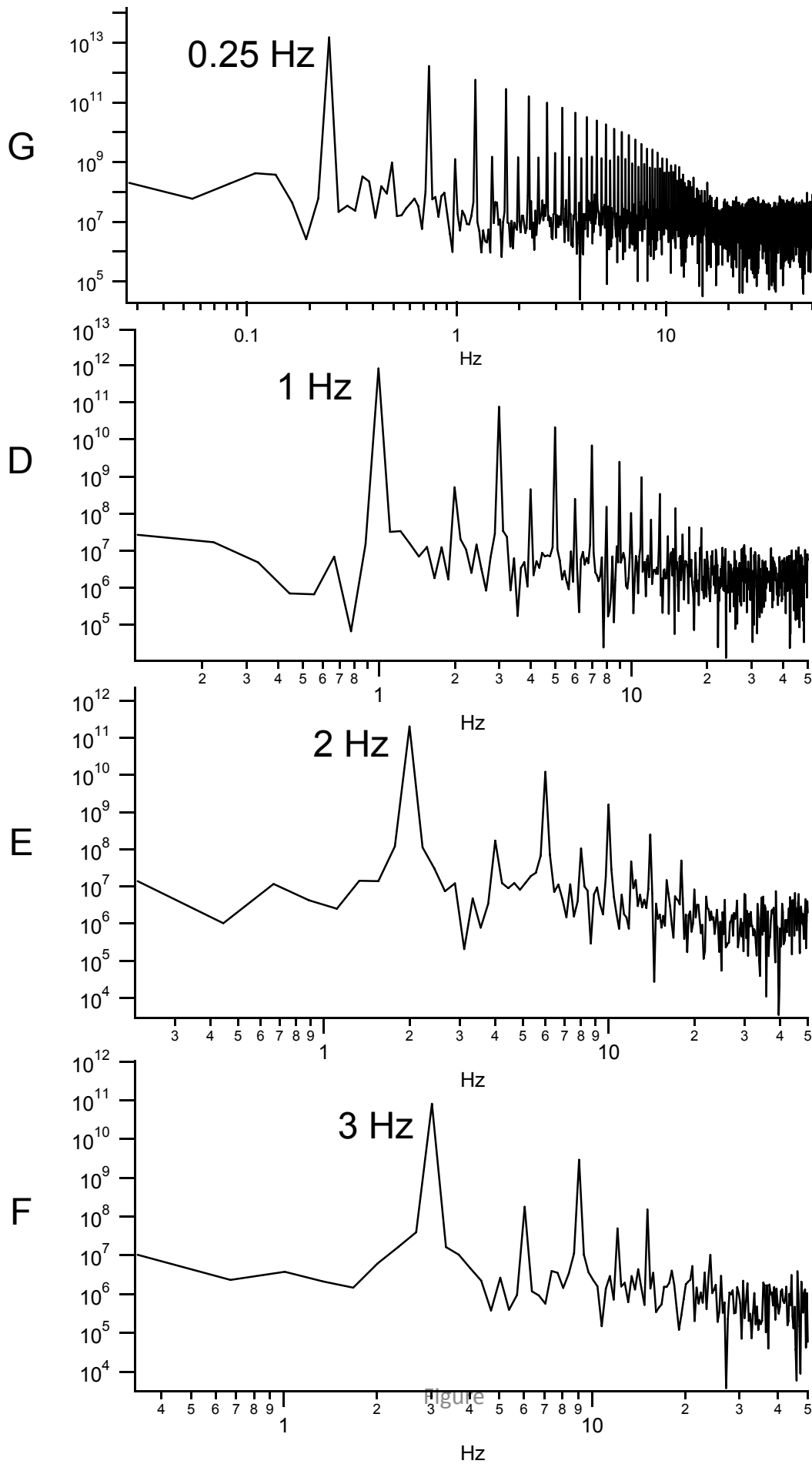

Figure

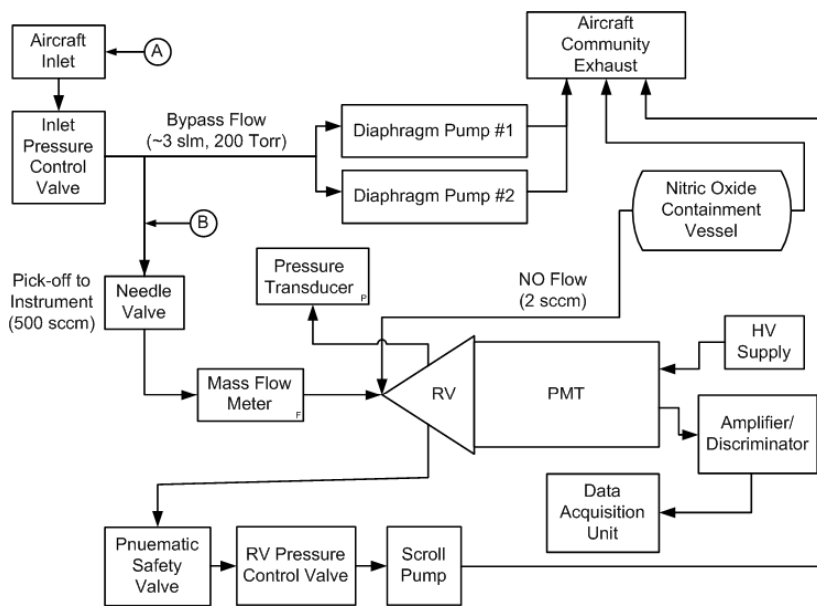

Figure