

Counterflow Virtual Impactor (CVI): Prior Results Related to ICE-T

24 September 2009

Measurements Made during ICE-L

4 instruments were part of basic CVI system; 5 additional instruments were located behind the CVI to measure drop/ice crystal residuals. All provided data!



← Droplets/ice crystals impacted & evaporated here

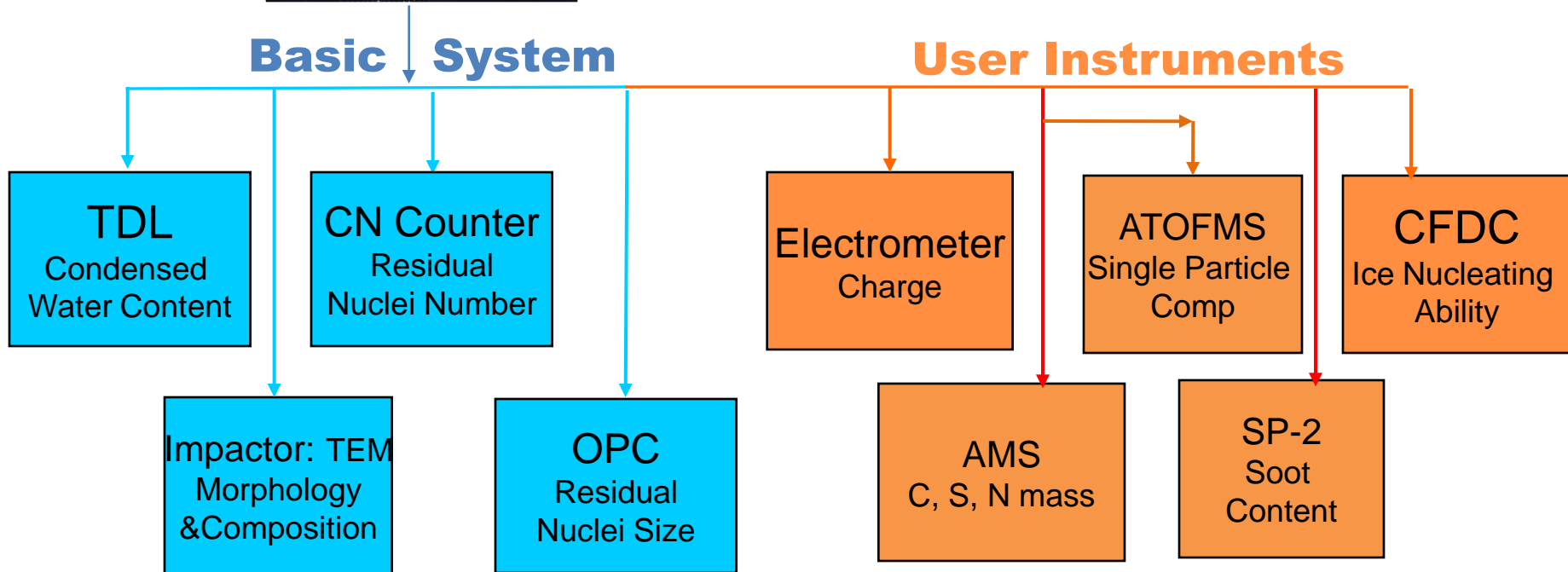

ICE-L Publications Using CVI Data

- Eidhammer et al. 2009: *Ice initiation by aerosol particles: Measured and predicted ice nuclei concentrations versus measured ice crystal concentrations in an orographic wave cloud*
- Field et al. 2009: *Contrasting the ice nucleation in two lee wave clouds observed during the ICE-L campaign*
- DeMott et al. 2009: *Advances toward predicting global ice nuclei distributions*
- Pratt et al. 2009: *In-situ detection of biological particles in high altitude dust-influenced ice clouds*
- Pratt et al. 2009: *Playa salts act as natural cloud nuclei*
- Twohy et al. 2009: *Relationships of biomass burning aerosols to ice in orographic wave clouds*
- Pratt et al. 2009: *In-situ chemical characterization of aged biomass burning aerosols impacting cold wave clouds*

Types of Particles Found in ICE-L

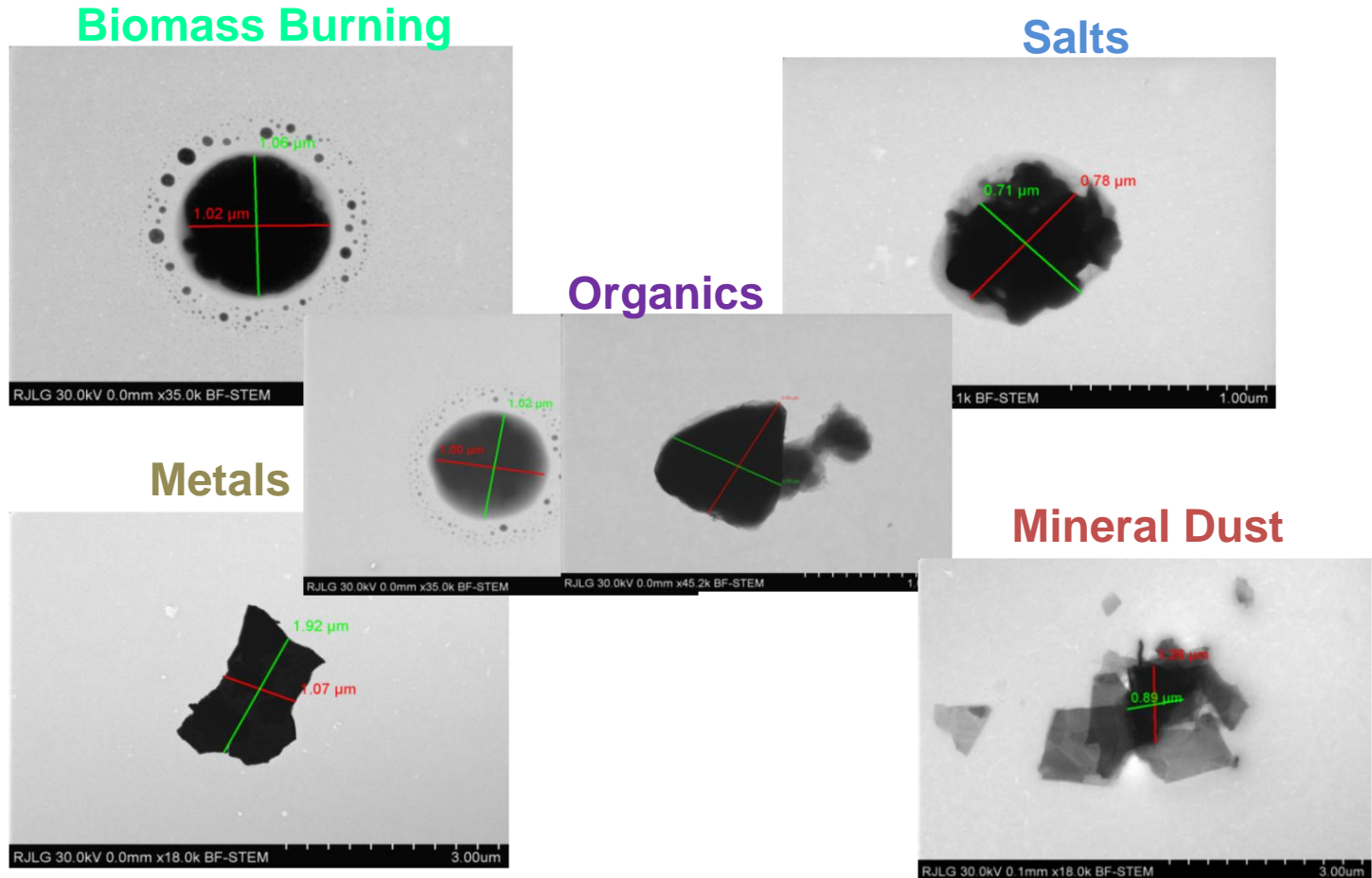

- Relatively few heterogeneous IN during ICE-L
- Some evidence that lakebed salts, organics made of biological material and biomass/black carbon particle types may be important
- Little mineral dust observed in ICE-L; however ICE-T likely to be impacted by Saharan dust, known to be strong heterogeneous IN

Measurements of Saharan Dust and Clouds in NASA African Monsoon Multidisciplinary Activities (NAMMA)



Does this dust act as Cloud Condensation Nuclei?

Lidar image of cloud embedded in SAL layer 5 Sept 06

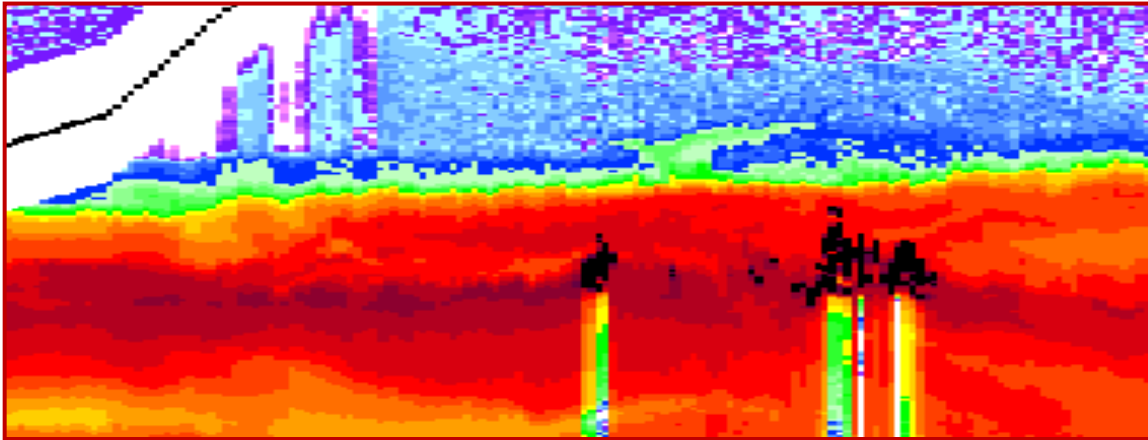

- Cloud residuals sampled with CVI in SAL contained nearly 80% pristine dust
- Even in small cumulus in MBL, about 1/3 of the droplets contained dust or dust mixed with soluble material
- Some nuclei down to $0.1 \mu\text{m}$ in size. (NOT giant CCN) .

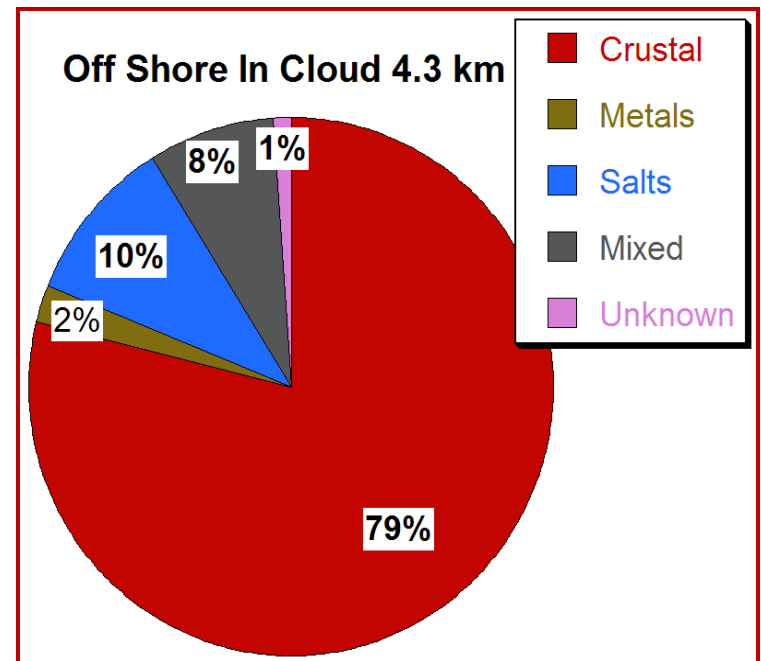

Why does this dust act as Cloud Condensation Nuclei?

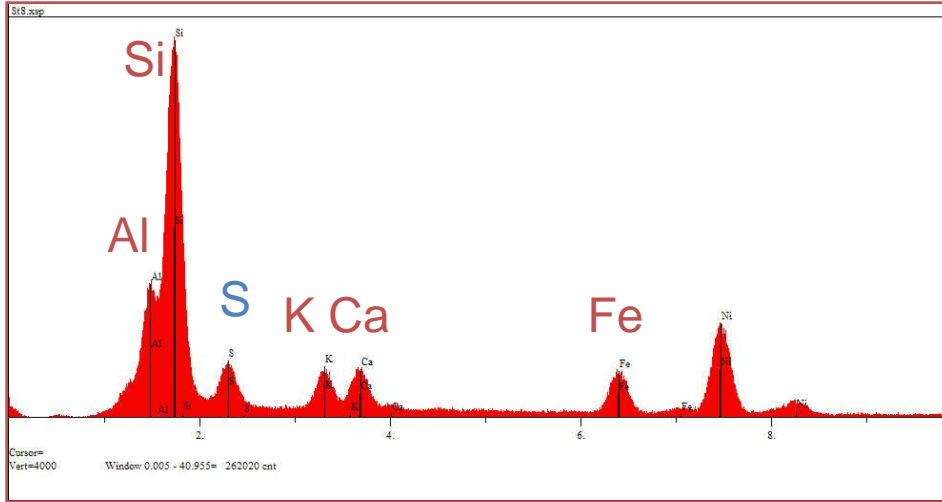

Measurements show fresh Saharan dust contains ~5% hygroscopic material (increases with atmospheric aging)

Saharan Dust: $Kappa = 0.05$

Competition between soluble salt with $d_g = 0.1 \mu m$, dust with $d_g = 0.6 \mu m$ and ~5% hygroscopic material

Slightly hygroscopic dust activates in similar fractions as all soluble material. Both size and composition imp

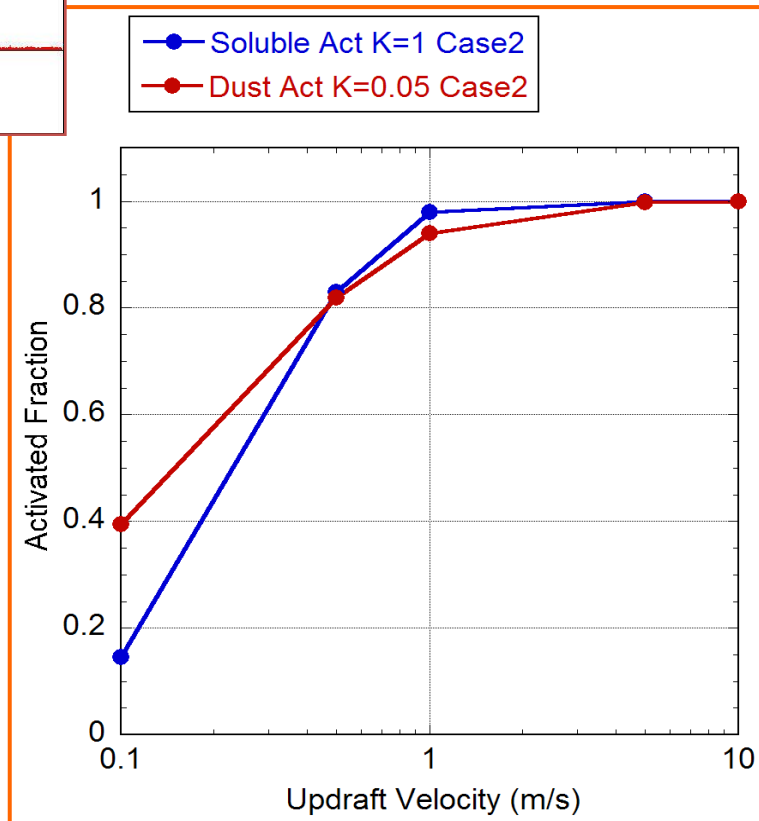

Twohy et al., GRL 2009

Does Dust Participate in Ice Process in Deep Convection?

NAMMA Tropical Storm Anvil Cirrus (-18>T>-45) Contain Copious Dust

12 Sept 2006 CVI Residuals
Particles 0.1-0.5 μm

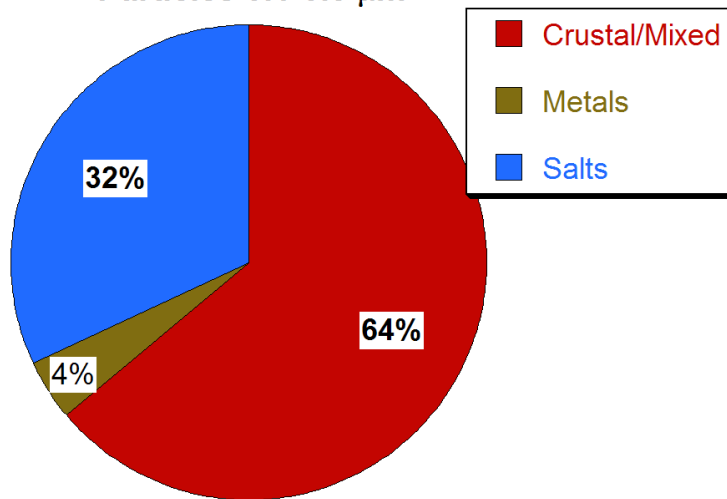

Sept 12 strong updraft case (T-45C),
~2/3 of cirrus residual particles contain dust

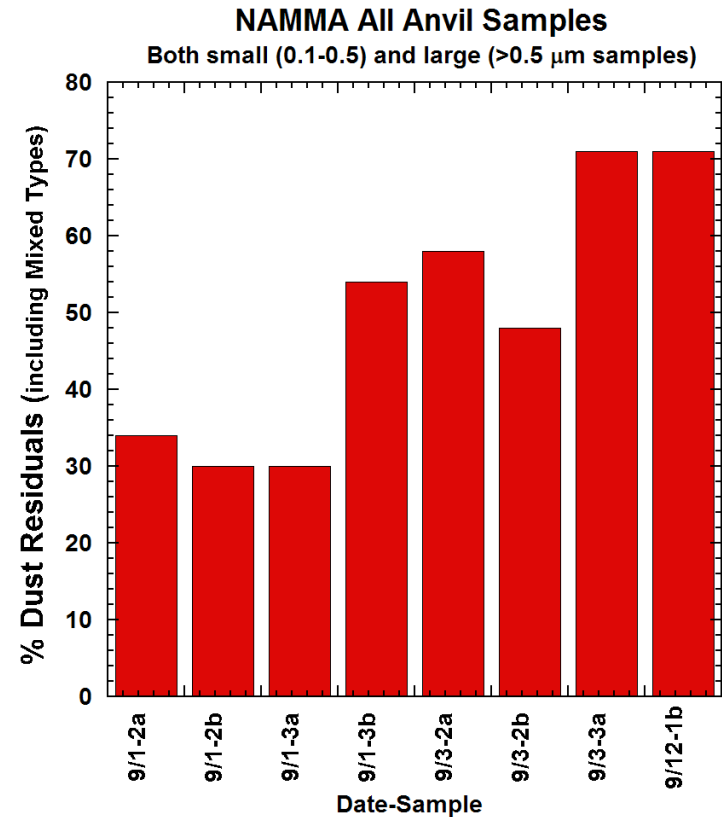

ALL anvils in eastern Atlantic contained dust.
If only a fraction of this dust reaches the
Caribbean, could enhance natural
background of (low) IN

What is impact of this dust acting as CCN, or as CCN and IN?

Begun simple RAMS simulation for dust acting as CCN or CCN + IN

Updraft in color (m/s). Liquid mixing ratio (black). Ice mixing ratio (white)

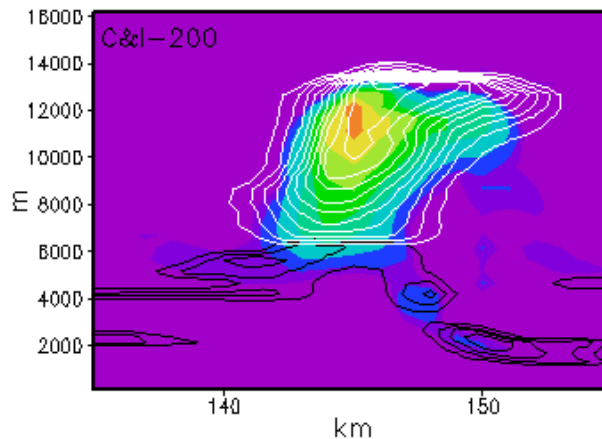
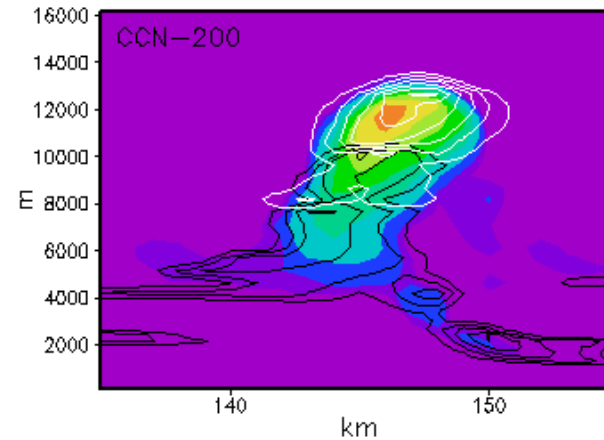
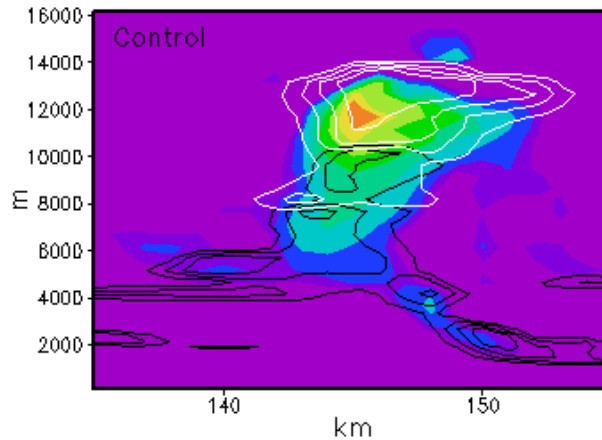

- Averaged spatially & temporally, 3x the ice at 9 km for CCN+IN case
- Aged anvil (not shown) deeper and thicker in CCN + IN case
- Also less precipitation in both cases due to warm rain suppression

