

**SC32A OPTICALLY ISOLATED  
RS232 INTERFACE  
INSTRUCTION MANUAL**

**REVISION: 1/93**

**COPYRIGHT (c) 1987, 1993 CAMPBELL SCIENTIFIC, INC.**

## WARRANTY AND ASSISTANCE

The **SC32A OPTICALLY ISOLATED RS232 INTERFACE** is warranted by CAMPBELL SCIENTIFIC, INC. to be free from defects in materials and workmanship under normal use and service for twelve (12) months from date of shipment unless specified otherwise. Batteries have no warranty. CAMPBELL SCIENTIFIC, INC.'s obligation under this warranty is limited to repairing or replacing (at CAMPBELL SCIENTIFIC, INC.'s option) defective products. The customer shall assume all costs of removing, reinstalling, and shipping defective products to CAMPBELL SCIENTIFIC, INC. CAMPBELL SCIENTIFIC, INC. will return such products by surface carrier prepaid. This warranty shall not apply to any CAMPBELL SCIENTIFIC, INC. products which have been subjected to modification, misuse, neglect, accidents of nature, or shipping damage. This warranty is in lieu of all other warranties, expressed or implied, including warranties of merchantability or fitness for a particular purpose. CAMPBELL SCIENTIFIC, INC. is not liable for special, indirect, incidental, or consequential damages.

Products may not be returned without prior authorization. To obtain a Returned Materials Authorization (RMA), contact CAMPBELL SCIENTIFIC, INC., phone (435) 753-2342. After an applications engineer determines the nature of the problem, an RMA number will be issued. Please write this number clearly on the outside of the shipping container. CAMPBELL SCIENTIFIC's shipping address is:

**CAMPBELL SCIENTIFIC, INC.**

RMA# \_\_\_\_\_  
815 West 1800 North  
Logan, Utah 84321-1784

CAMPBELL SCIENTIFIC, INC. does not accept collect calls.

Non-warranty products returned for repair should be accompanied by a purchase order to cover the repair.



## CAMPBELL SCIENTIFIC, INC.

815 W. 1800 N.  
Logan, UT 84321-1784  
USA  
Phone (435) 753-2342  
FAX (435) 750-9540  
www.campbellsci.com

Campbell Scientific Canada Corp.  
11564 -149th Street  
Edmonton, Alberta T5M 1W7  
CANADA  
Phone (403) 454-2505  
FAX (403) 454-2655

Campbell Scientific Ltd.  
Campbell Park  
80 Hathern Road  
Shepshed, Leics. LE12 9RP  
ENGLAND  
Phone (44)-50960-1141  
FAX (44)-50960-1091

# SC32A OPTICALLY ISOLATED RS232 INTERFACE

## 1. FUNCTION

The SC32A interfaces an RS232 peripheral, commonly a computer or printer, to the Serial I/O of a CSI datalogger. The SC32A replaces the SC32. Functions include:

1. Converting datalogger logic levels to RS232 logic levels.
2. Optically isolating the datalogger and the RS232 peripheral. Optical isolation separates the SC32A into a datalogger section and an RS232 section. Signals entering from either side are electrically independent, protecting against ground loops, normal static discharge, and noise.
3. Passing data when pins 5 or 6 of the datalogger I/O are high and the on-board jumper is removed (see SC32A Component Location Diagram, Figure 5.1).
4. Passing data when pin 5 is high and pin 6 is low when the jumper is in place.

SC32As with serial numbers less than 1500 were shipped with the jumper in a blocking position (two posts connected). Serial numbers 1500 and greater are shipped with the jumper on one post only, in the passing position.

When used with a CR10 Measurement and Control Module, the correct SC32A jumper position depends on the application. For all

other CSI dataloggers, the jumper has little effect and could be removed (Section 5).

## 2. SPECIFICATIONS

Operating temperature: -25 to +50 °C (typical)

Power: Powered by host devices, see "Operation" section

Ports: 25 pin (sockets) configured as DCE. 9 pin (pins) connect to CSI datalogger through SC12 Two Peripheral Cable (included)

Size: 2.25 x 1.0 x 3.5 inches, 0.25 lbs.

## 3. CONNECTOR DESCRIPTIONS

### 3.1 25 PIN

The SC32A 25 pin female port is configured as Data Communications Equipment (DCE) for direct cable connection to Data Terminal Equipment (DTE). Most terminals, computers, and printers are configured as DTE. For connection to DCE devices such as modems and some computers, a null modem is required. A null modem configuration is given under "Special Cases", Section 5.3.

### 3.2 9 PIN

The SC32A 9 pin male port connects to the datalogger through the SC12 Two Peripheral Cable supplied with the SC32A. Pin descriptions and direction (Input/Output) are given in Table 3.1.

**TABLE 3.1 SC32A CONNECTOR DESCRIPTIONS**

25 PIN FEMALE CONNECTOR			9 PIN MALE CONNECTOR		
PIN #	I/O	DESCRIPTION	PIN #	I/O	DESCRIPTION
1		GROUND	1	IN	+5V
2	IN	TX	2		GROUND
3	OUT	RX	3	OUT	RING
4	IN	RTS (POWER)	4	OUT	RX
5	OUT	CTS	5	IN	ME
6	OUT	DSR	6	IN	PE (CR10 SDE)
7		GROUND	9	IN	TX
8	OUT	DCD			
20	IN	DTR (POWER)			

## SC32A OPTICALLY ISOLATED RS232 INTERFACE

### 4. OPERATION

Power for the SC32A datalogger section comes from the 5V supply on pin 1 of the datalogger I/O. Communication logic levels to and from the datalogger are referenced to this voltage, ranging from 0 to slightly less than 5V.

Power for the RS232 section is taken from the Data Terminal Ready (DTR) and Request To Send (RTS) lines of the RS232 peripheral. An on-board DC to DC converter supplies the negative voltage required for RS232 signals. Absolute magnitude of the logic levels from the SC32A to the RS232 peripheral are 0.6V less than supply voltage. For example, if the DTR line supplies 9V to the SC32A, logic levels of !!+!! 8.4V are returned. If the peripheral requires logic levels greater than the voltage provided by the DTR and RTS voltages, an external supply may be used to power the RS232 side of the SC32A (see "Special Cases", Section 5.3).

When the SC32A first receives a character from the peripheral (pin 2), 5V is applied to the datalogger Ring line (pin 3) for one second or until the datalogger Modem Enable (ME) goes high, putting the datalogger into the Telecommunications Mode.

RS232 cables of up to 200 feet have been used between the SC32A and the IBM Personal Computer at 9600 Baud. The length of cable that can be used is largely dependent on the RS232 DTR and RTS drive capability as well as the RS232 RX operating thresholds.

### 5. APPLICATION

The CR21, 21X, and CR7 dataloggers communicate with a peripheral by enabling it with an assigned I/O pin. The CR10 design preserves this enabling system for compatibility with peripherals, but also introduces a new synchronous addressing scheme to select peripherals. The addressing system allows up to 16 peripherals to be selected for communication, whereas the pin enable system is limited by the number of pins available for the enabling task (3). Correct use of the SC32A not only depends on the general category of datalogger involved but also, within the CR10 category, how the peripheral is activated (pin enabled or address selected) and how many peripherals are present.

In the following discussion, the term enable refers to that method which activates a peripheral by setting an assigned datalogger I/O pin high. The term address is reserved for that method which selects peripherals through addressing.

#### 5.1 SC32A WITH 21X AND CR7 DATALOGGERS

This category of dataloggers enables peripherals for communication. The SC32A is a modem-type peripheral, and only one modem may be connected to these dataloggers at one time. With two modems connected, the magnitude of a logic high is too low for proper communication.

There are three cases where the SC32A could be used with this category of dataloggers:

**Case 1.** An SC32A interfaces a terminal/computer to the datalogger and no pin 6 enabled peripherals are connected. In this case, the datalogger is in the telecommunications mode and all data transfer is a result of pin 5 being enabled. The jumper may be connected or removed.

**Case 2.** An SC32A interfaces an RS232 printer-type peripheral. The jumper must be removed because data is sent to the peripheral only when pin 6 is enabled. Keeping in mind that only one modem can be connected to a datalogger at one time, data transfer resulting from telecommunications (pin 5 high) is impossible in this situation.

**Case 3.** An SC32A interfaces a terminal/computer to the datalogger and at least one other pin 6 enabled peripheral is directly connected to the datalogger (Printer or Storage Module). The dataloggers are designed to delay output to a pin 6 enabled peripheral while pin 5 is active (i.e.; there is no output to peripherals while in the telecommunications mode). When telecommunications is exited, pin 5 is set low and output to pin 6 enabled peripherals is resumed. If the terminal/computer is left on, the SC32A jumper is removed, and the baud rate is compatible, data going to pin 6 peripherals will also appear at the terminal/computer. With the jumper in place, data will be blocked.

**5.2 SC32A AND A CR10 DATALOGGER**

To understand where the SC32A can be used and the significance of the jumper, a short discussion of the datalogger I/O interaction is necessary.

The CR10 enters telecommunications in two ways. Pin 5 enables phone modems and the SC32A for phone telecommunications. To achieve telecommunication through a RF modem or CR10KD Keyboard Display, the CR10 addresses the appropriate peripheral using a combination of the Synchronous Device Enable (SDE, pin 6), Clock/Hand Shake (CLK/HS, pin 7) and Transmit (TX, pin 9; further discussion on addressing is found in the CR10 Operator's Manual, Section 6). Addressable peripherals include the SM192/716, CR10KD, SDC99 Synchronous Device Interface, and the RF95 (in SDC state). In addition to the addressing process, the SDE line also enables peripherals like the PE line of the 21X and CR7 dataloggers. Simultaneous use of addressed and pin 6 (SDE) enabled peripherals should be avoided. When addressing occurs, enable-type peripherals will receive address information which, at a minimum, will mix garbage in with data, and at worst, cause the peripheral to lock-up and become inoperative.

In most cases, if the SC32A is used between the CR10 and some peripheral, and addressable peripherals are also present, the jumper should be in place. This will block addressing information from reaching the SC32A interfaced peripheral. The only situation in which the jumper may safely be removed is if the SC32A is interfacing the only peripheral attached to the CR10 (with the exception of cassette tape).

The jumper should be in place when interfacing a terminal/ computer.

Any printer-type peripheral which is interfaced to the CR10 through an SC32A may become an addressable peripheral with the addition of the SDC99 Synchronous Device Interface. The SDC99 is located between the SC32A and the datalogger. Data is allowed to get to the SC32A only if the SDC99 is addressed. After being addressed, the SDC99 raises pin 6 of the SC32A; thus, the jumper must be removed.

An SC32A may be used to interface a computer to a CR10 which also has an RF95 (in SDC state) attached. This is the only situation in which two modems may be operating simultaneously on one datalogger.

**5.3 SPECIAL CASES**

Null Modem - A null modem is required only if the RS232 device connecting to the SC32A is configured as Data Communications Equipment (DCE). Wiring between two RS232 connectors for creating a null modem is shown below.

**TABLE 5.1 NULL MODEM CONFIGURATION**

SC32A SIDE		RS232 SIDE
25 PIN CONNECTOR		25 PIN CONNECTOR
PIN #	CONNECTS TO	PIN #
1		1
7		7
2		3
3		2
6		20
4 and/or 20	TO A LINE THAT IS LOGIC HIGH	

**NOTE:** The side of the null modem connecting to the SC32A must be male. The gender of the other side is dependent on the mating connector going to the computer.

External Power Supply - Two situations have been identified where an external power supply is required for the RS232 side of the SC32A.

1. Input logic levels required by the Data Receive of the RS232 device exceeded the output level of the RTS and DTR.
2. RTS and DTR lines which power the SC32A are absent from the cable going to the RS232 device.

The most common external supply will be either a 6 or 12 VDC battery. Any supply over 9V must have a series resistor to limit the current to 25 mA or less. If a 12V supply is used, a 120 Ohm resistor, or greater, is required to be in series with the plus (+) lead of the battery. These voltage and current limitations prevent the DC to DC converter from being damaged.

# SC32A OPTICALLY ISOLATED RS232 INTERFACE

External power connections to the SC32A are given below:

Ensure that the ground of the RS232 device and the external supply are tied together.

SC32A 25 PIN PORT  
PIN #

4 and/or 20

1 and/or 7

EXTERNAL POWER  
SUPPLY

+

-

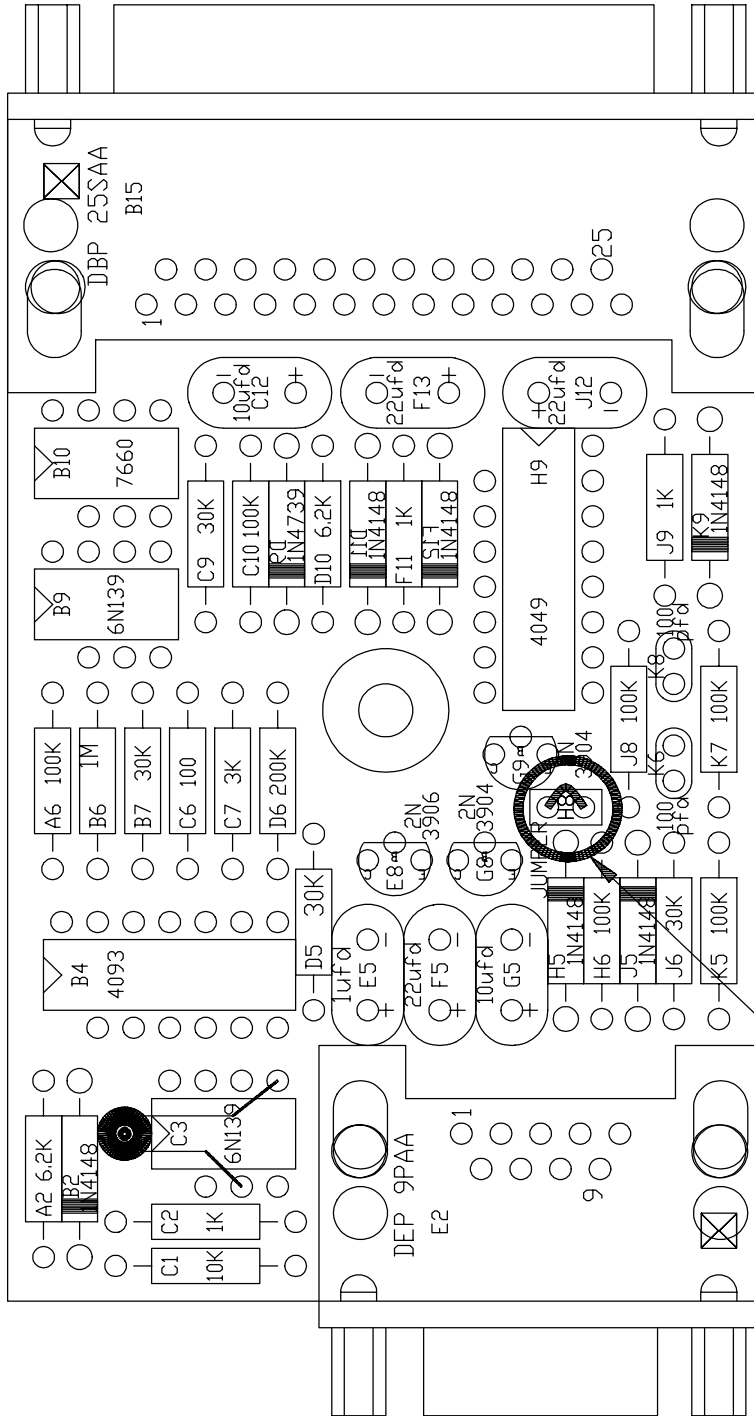

DESIGNED BY: John H.	PROJECT MANAGER: Kent Reid	DATE OF LAST REV: 08-03-89	SIG:
DESCRIPTION: SC32A Optically Isolated Interface			PAGE: 1 of 1
CAMPBELL SCIENTIFIC INC			DOCUMENT NUMBER: ADR_3915-04

copyright (c) 1991  
Campbell Scientific, Inc.

JUMPER

FIGURE 5.1 Component Location Diagram

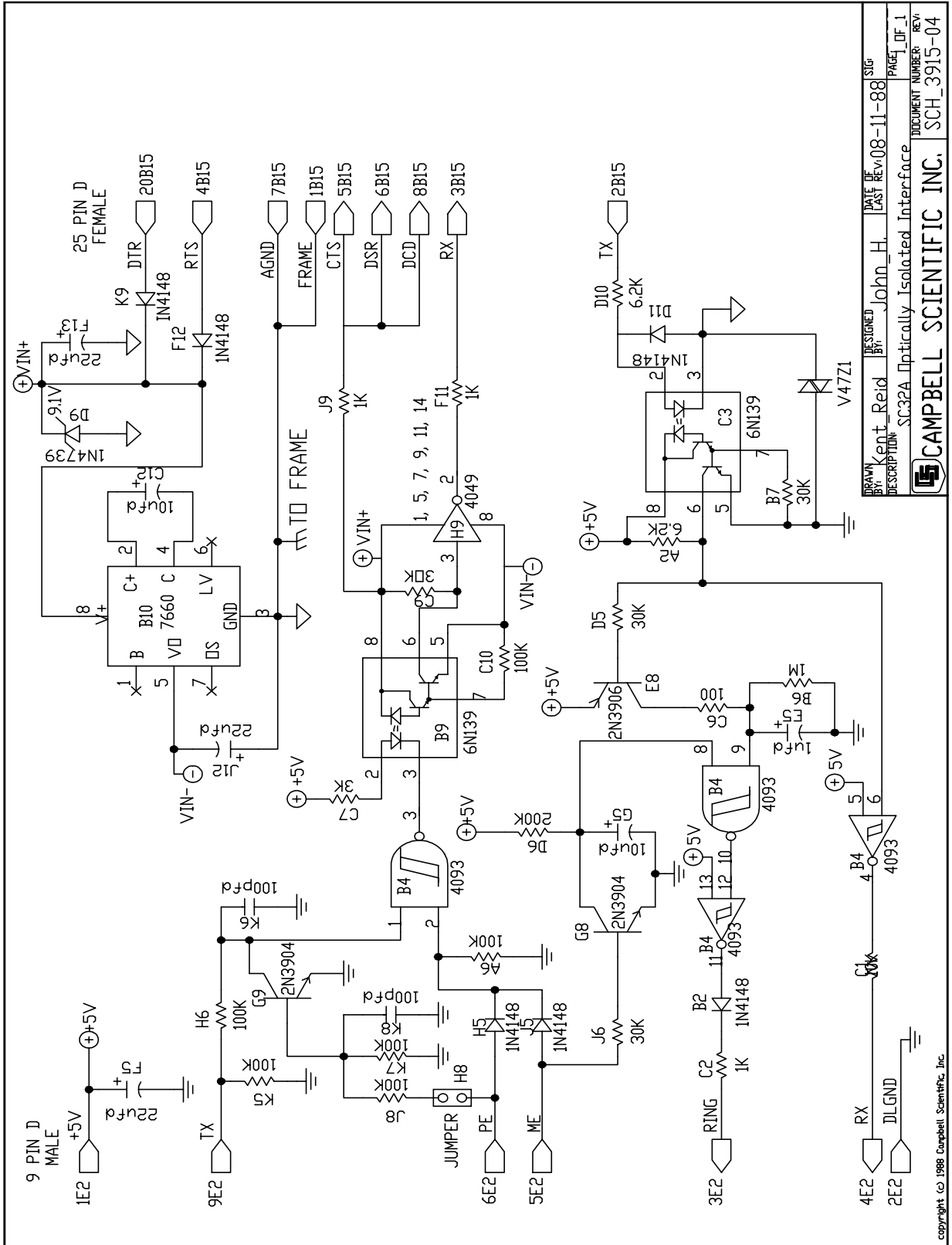

DESIGNED BY:	John H. Reid	DATE OF LAST REV:	08-11-88	SUP:
DESCRIPTION:	SC32A Optically Isolated Interface			
DOCUMENT NUMBER:	SCH_3915-04			
PAGE:	1 OF 1			



copyright © 1988 Campbell Scientific, Inc.

FIGURE 5.2 SC32A Schematic